

FLEXIBLE, SCALABLE, SUSTAINABLE

# E-MOVER

Patented automated guided vehicle technology  
for the whole paint shop

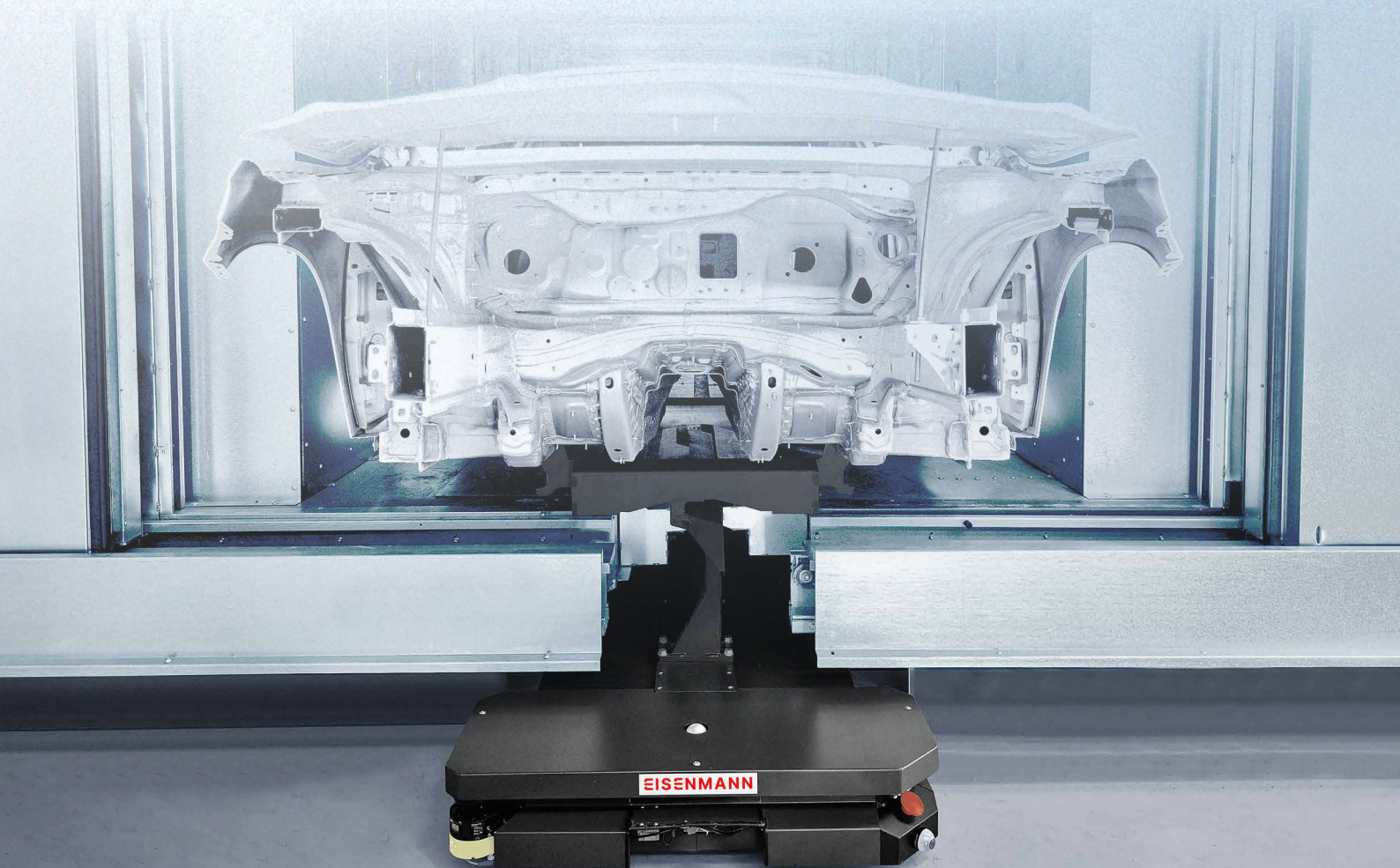

## **E-MOVER**

### Application for automated guided vehicles for full flexibility and scalability in the paint shop

The factory of the future knows no rigid workflows and processes – the goal is nothing less than series production with batch size 1. This requires intelligent, flexibly designed conveyor systems that clear the way for the production of a wide variety of workpieces, car bodies and vehicle models on one and the same system.

In the course of a consistent further development of the skidless paint shop, Eisenmann has developed the E-Mover, a driverless transport system for special applications in car body painting, which can be designed either as a E-Mover Paint for the skidless transport of vehicle bodies through the paint shop processes or as a E-Mover Store for scalable surface storage. With this, we are not only setting accents in terms of sustainability – our innovative spirit was also rewarded with a patent for the application of the driverless transport system in the body paint shop.

However, the advantages of the E-Mover are not only interesting for car manufacturers. Companies from the metalworking industry, such as manufacturers of housings, radiators, agricultural, construction and machine tools, also benefit from its versatile application possibilities.

**Jörg Robbin, Head of Research & Development, Eisenmann GmbH**

We develop ecological products that are economically attractive. Our principle is that sustainability does not have to be expensive. And we find out for each customer what is really necessary – what I don't need, I don't have to pay for. This makes both the investment and the operation of the system cheaper.



The technology of the E-Mover transports loads of up to 1,500 kilograms. It can be moved omnidirectionally and thus enables the most compact driving styles. Eight drives, which can also run in „all-wheel mode“, allow almost abrasion-free turns on the spot. Controlled by a master computer, it finds its way to its destination at a speed of up to 1.5 metres per second via an optical guidance system or in free navigation.



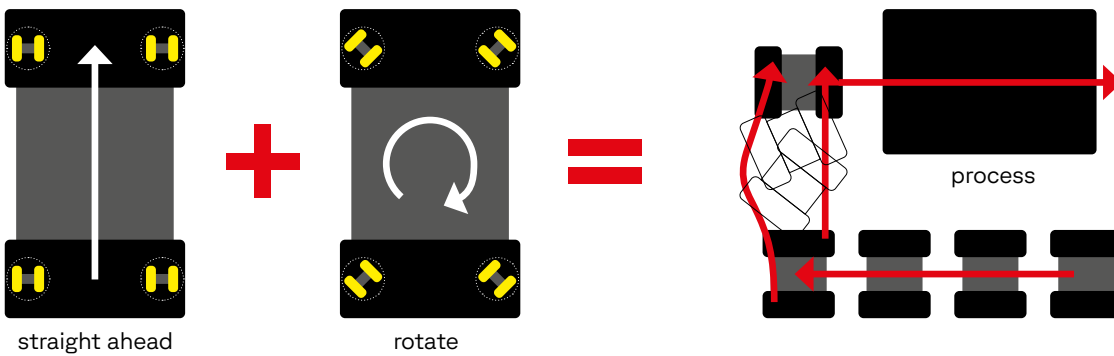

The omnidirectional driving enables to perform several movements superimposed.

## Reliable vehicle control

The built-in LiDAR system provides orientation by measuring its surroundings and thus generating a 360-degree protective field. Equipped with this, the E-Mover automatically reduces its speed when obstacles enter the detection range. This makes it safe for people in terms of collision protection and enables simultaneous use of existing travel paths by the transport system and people.



The exclusive use of tried and tested industry standard components ensures easy maintenance and reliable spare parts supply for many years. Thanks to a secure communication protocol developed by Eisenmann, the E-Mover and stationary safety equipment are optimally networked via W-LAN.

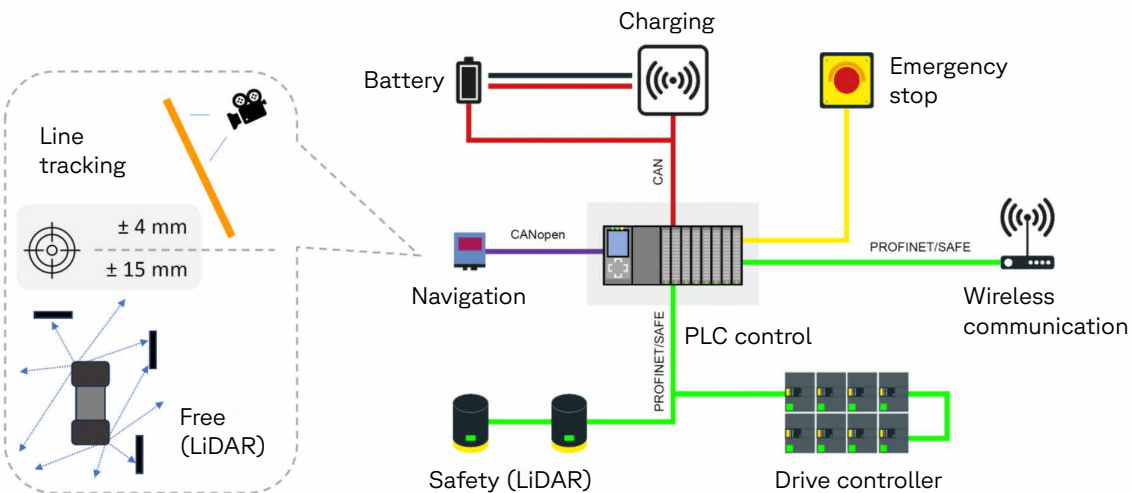

## Sustainable battery concept

The sustainable battery concept means that the E-Mover can manage without recharging the batteries for the entire period of a shift. Recharging is possible at any time with an efficiency of up to 93% without contact. With our standard charging system, a wide variety of battery types can be used, which easily allows adaptations to future battery technology.









Sustainable battery concept

## E-MOVER PAINT

### Maximum scalability and efficiency in the coating process

The product E-Mover is the result of a consequent further development of the skidless paint shop. Usually, vehicle bodies are conveyed through the paint shop on a steel slide (skid). With our unique approach, we now save the rigid conveyor technology and use our automated guided vehicle with which we convey through the entire process flexibly and without a skid. This saves energy because the skid no longer needs to be heated up and cooled down unnecessarily during the painting process. This saves resources and is therefore sustainable.



-  **1.2 ... 90 m/minute**
-  **Payload : 1,500 kg**
-  **Flexible lithium battery concept**
-  **Wireless charging**
-  **100% charge in 1 hour**
-  **W-LAN**

## E-MOVER STORE

### Designing flexible, intelligent and versatile storage areas with the E-Mover Store

In addition to the functions of the E-Mover Paint, the E-Mover Store has an integrated lifting device. It drives under the bodies, lifts them and transports them to a defined destination. The E-Mover Store can transport the bodies with or without skid.

VarioStore offers the greatest possible flexibility for area relocations and capacity changes, as it uses any free space.

Furthermore, the system guarantees access to every stored body at any time. There are transport aisles between the rows, which ensure a fast transport time with maximum efficiency. To achieve this, the E-Mover can also drive under parked bodies and thus does not block any transport path.



E-Mover in the application in the area storage

## Lower investment costs

If the E-Mover Store is used in an existing area, the investment costs can be significantly reduced.



The greatest savings potential is offered by the elimination of a complete high-bay warehouse consisting of stacker cranes and conveyor technology in the pre-rack zone. In addition, the capacity of the entire warehouse can be flexibly expanded and thus grow with the needs of the paint shop. As a result, the paint shop is able to achieve the required throughput at all times, even when requirements change.

## Our guiding principle

Eisenmann combines flexible hardware, intelligent software and digital services that work together to provide maximum customer benefit.

## Advantages at a glance

- Fast and compact transport due to skidless, omnidirectional travel mode
- Highly flexible and scalable use in case of area relocations and capacity changes
- Any access to required car bodies possible at any time
- No protective grids necessary outside processes
- Investment cost savings



## More information about E-Mover?

### Contact:



### Product Manager

Dr. Axel Eipper

Phone: +49 7031 78-2675

Mail: axel.eipper@eisenmann.com



[www.eisenmann.com](http://www.eisenmann.com)

Eisenmann GmbH, Tübinger Str. 81, 71032 Böblingen, Germany, Phone: +49 7031 78-0, Fax: +49 7031 78-1000



2025 © Eisenmann GmbH | 11-2025

All rights reserved. All text, images, photos and graphics are subject to copyright and other intellectual property laws. Content may only be used with the express permission of Eisenmann Anlagenbau GmbH. All content, including, without limitation, specifications, descriptions and illustrations, are subject to error and change, in particular with regard to ongoing development of our products in line with technological progress. Changes to content will not be proactively communicated. Technical specifications may vary from country to country.